

AV-SIGN-20 Solar LED Sign Light

Typical Applications

- Solar LED Sign Light

Major Benefits

- Area illumination
- Sign lighting
- Ultra high-intensity LEDs
- Extremely low maintenance
- Automatic night activation

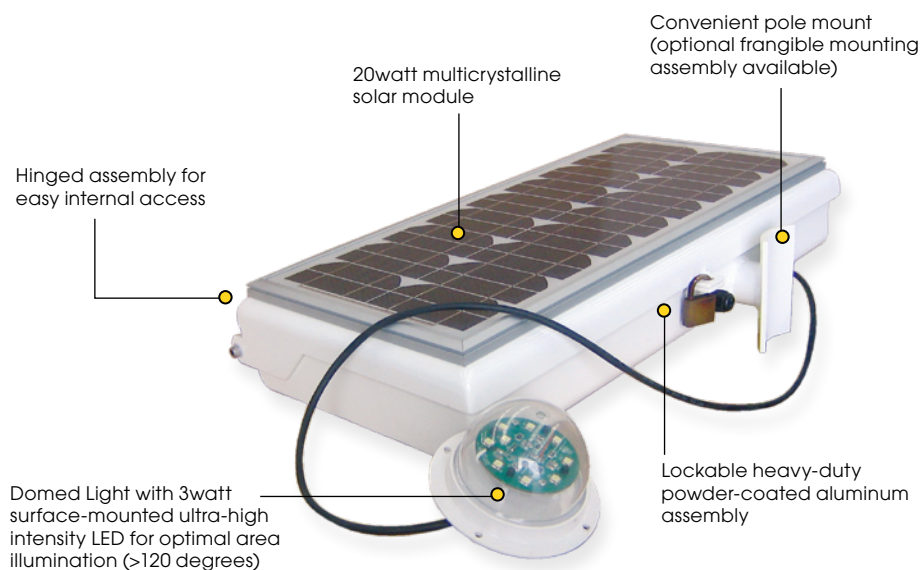

Avlite System's Solar LED Sign Light is a remote solar-powered signage light specifically designed for airfield signage illumination.

The unit can be fitted with either 1 or 2 domed LED light fixtures, each featuring a 3 watt surface-mounted ultra-high intensity LED for maximum illumination with an even 120 degree light spread.

The light fixture also features a domed UV stabilized LEXAN® polycarbonate lens and base, and convenient mounting bracket ensuring flexibility and ease of installation.

The Power Box, consisting of a 20watt multicrystalline solar module, 18Ah SLA battery and charge regulator, is made from 7-stage powder-coated aluminum making the unit extremely robust. The Solar LED Sign Light is designed to withstand a range of environmental conditions, and once installed requires minimal maintenance.



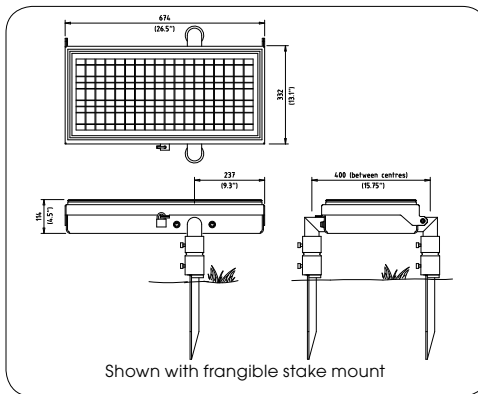
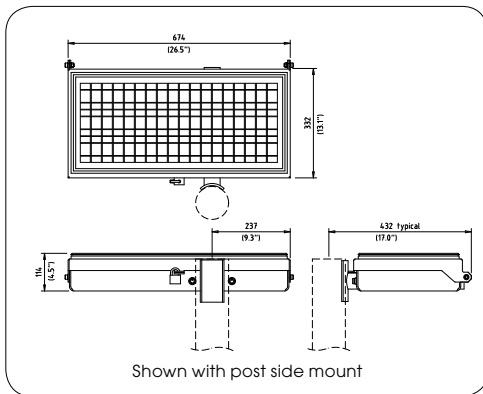

SPECIFICATIONS •

Light Characteristics

Light Source	1 LED cluster in LEXAN® domed luminaires (standard)
Available Colours	White
Light Divergence (degrees)	120
LED Life Expectancy (hours)	100,000

Electrical Characteristics

Current Draw (mA)	250mA per light
Circuit Protection	Integrated
Operating Voltage (v)	12
Autonomy (days)	6
Temperature Range	-40 to 80 °C

Solar Characteristics

Solar Module Type	Multicrystalline
Output (watts)	20
Solar Module Efficiency (%)	14
Charging Regulation	Regulated

Power Supply

Battery Type	SLA (Sealed Lead Acid)
Battery Capacity (Ah)	18
Nominal Voltage (v)	12

Physical Characteristics

Body Material (Domed Light Source)	LEXAN® Polycarbonate – UV stabilized
Lens Material	LEXAN® Polycarbonate – UV stabilized
Body Material (Power Box)	7-stage powder-coated aluminum
Mounting	Post or stake mount available
Mass (kg/lbs)	9 / 19 ³ / ₄
Product Life Expectancy	Up to 12 years

Certifications

CE	EN61000-6-3:1997, EN61000-6-1:1997
Quality Assurance	ISO9001:2000

Intellectual Property

Trademarks	AVLITE® is a registered trademark of Avlite Systems
------------	---

Warranty

Full 3 year warranty

Options Available

- Mounting assemblies

CE

- Specifications subject to change or variation without notice